



ZAWIASY
DO PCV





ZAWIASY
DO PCV
AXM / EXM



ZAWIAS DO PCV AXM

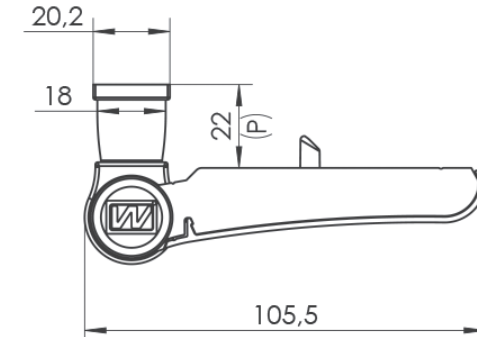
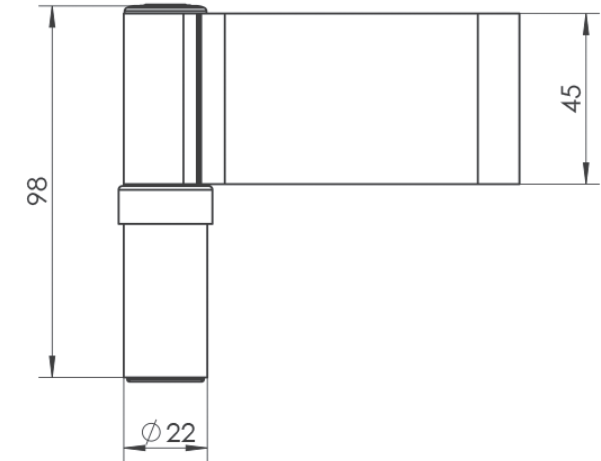
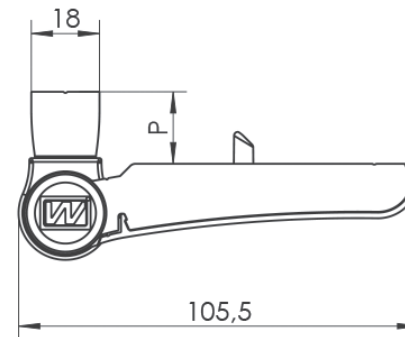
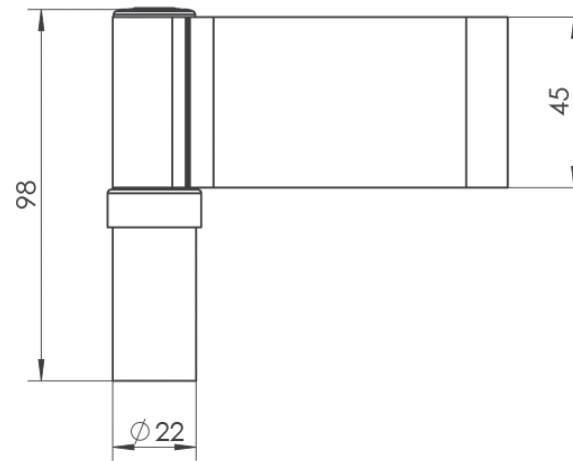

P – wartość przyłgi w położeniu zerowym:

AXM 17... – 17mm (14 - 20mm)

AXM 19... – 19mm (16 - 22mm)

AXM 21... – 21mm (18 - 24mm)

Za pomocą podkładki tworzywowej dystansowej 3 mm realizowana może być przyłga 19 mm, 22 mm lub 24 mm.





ELEMENTY MOCUJĄCE
OŚCIEŻNICY
DRZWIOWEJ



ELEMENTY MOCUJĄCE
SKRZYDŁA
DRZWIOWEGO

ZAWIAS DO PCV EXM

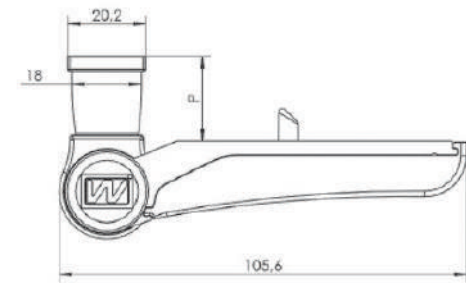
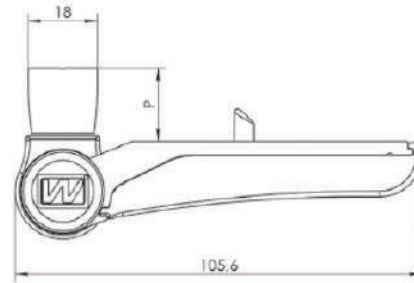
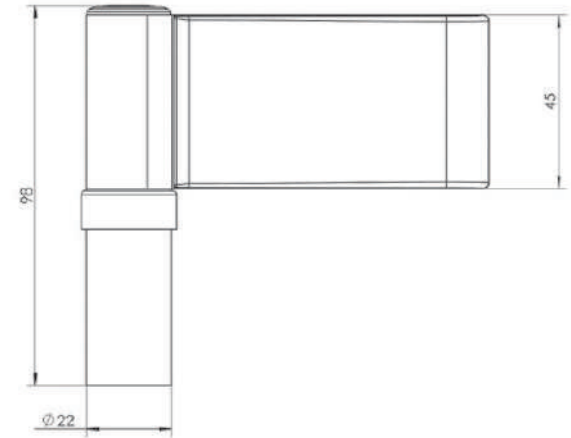
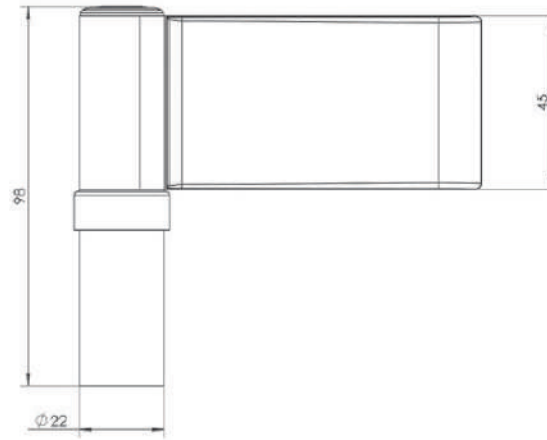

P – wartość przyłgi w położeniu zerowym:

AXM 17... – 17mm (14 - 20mm)

AXM 19... – 19mm (16 - 22mm)

AXM 21... – 21mm (18 - 24mm)

Za pomocą podkładki tworzywowej dystansowej 3 mm realizowana może być przyłga 19 mm, 22 mm lub 24 mm.



ZAWIASY DO PCV AXM / EXM

DO STOSOWANIA W DRZWIACH NA DROGACH EWAKUACYJNYCH

**KLASYFIKACJA ZAWIASU AXM / EXM
WG EN 1935:2002 + EN 1935:2002/AC:2003**

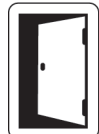

4/4 - KATEGORIA UŻYTKOWANIA



7/7 - TRWAŁOŚĆ



6/7 - MASA DRZWI PRÓBNYCH



0/1 - ODPORNOŚĆ OGNIOWA



1/1 - BEZPIECZEŃSTWO UŻYTKOWANIA



4/4 - ODPORNOŚĆ NA KOROZJĘ



1/1 - ODPORNOŚĆ PRZECIWWŁAMANIOWA



13/14 - KLASA ZAWIASU



DOBÓR OBCIĄŻENIA ZAWIASÓW DO PCV AXM / EXM

Jeśli rozstaw między zawiasami w środku jest większy niż 1500mm, sugerujemy zastosowanie zawiasu doszczelniającego.



Budownictwo
prywatne



Budownictwo
publiczne



Samozamykacz



2-skrzydłowy



3-skrzydłowy

W	S	800	900	1000	1100	1200	1300	1400
		2000	135	125	110	100	95	85
2100	130	120		105	100	90	85	
2200	135	135		130	115	105	95	90
2300				125	115	105	95	
2400	135	135		135	120	110	100	
2500					125	115	105	
2600	135	135		135	120	110		
2700					130	120		
2800	135	135		135	135	125		
2900						130		
3000	135							

W	S	800	900	1000	1100	1200	1300	1400
		2000	110	100	85	75	70	60
2100	105	95		80	75	65	60	
2200	110	110		105	90	80	70	65
2300				100	90	80	70	
2400	110	110		110	105	100	85	75
2500					105	90	80	
2600	110	110		110	110	95	85	
2700						105	95	
2800	110	110		110	110	100		
2900						105		
3000	110							

W	S	800	900	1000	1100	1200	1300	1400
		2000	100	90	75	65	70	60
2100	95	85		70	75	65	60	
2200	100	95		80	80	70	65	
2300	110	110	110	100	90	80	70	
2400				105	100	85	75	
2500				105	90	80		
2600				95	85			
2700				105	95			
2800				110	110	110	100	
2900							105	
3000				110				



REGULACJA ZAWIASÓW DO PCV AXM / EXM

Regulacja docisku
uszczelki (przyłgi)
 $\pm 3 \text{ mm}$

Regulacja
wysokości
 $+ 5 \text{ mm}$
 $- 1,5 \text{ mm}$

Regulacja
lewo/prawo
 $\pm 5 \text{ mm}$

Regulacja docisku
uszczelki (przyłgi)
 $\pm 3 \text{ mm}$

Regulacja
wysokości
 $+ 5 \text{ mm}$
 $- 1,5 \text{ mm}$

Regulacja
lewo/prawo
 $\pm 5 \text{ mm}$



SZABLONY WIERCENIA DLA ZAWIASÓW AXM / EXM

AXM / EXM



**GRUBOŚĆ
DYSTANSU A**

WARTOŚĆ X

2 mm

34 mm

4 mm

32 mm

6 mm

30 mm

8 mm

28 mm

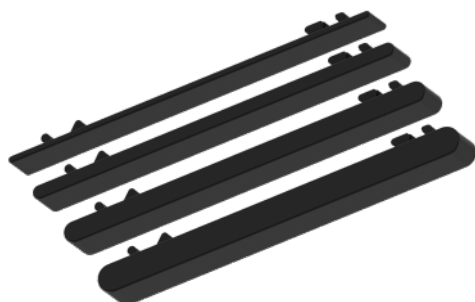

POTRÓJNY SZABLON







WALA Sp. z o.o.
ul. Parkowa 16
43-365 Wilkowice

wala@wala.pl
tel. +48 33 82 72 390
kom. +48 725 70 80 30
www.wala.pl

